



IN-LINE BATTERY CHARGER SPECIFICATION SHEET

Highest Quality · Longest Life · More Power

THE INDUSTRY'S PROVEN CHOICE FOR MOTIVE POWER BATTERY SYSTEMS.

Introducing Battery Builders' custom lead-acid battery tray with an integrated charger: the ultimate solution for seamless motive power management. Engineered for reliability and convenience, our in-line battery charger ensures your lead-acid battery is always charged and ready. Combining robust construction with smart technology to optimize performance and extend battery life, our innovative solution guarantees dependable power when you need it most.

OVERVIEW

- BBI's **18-085-21-1999-B** combines our popular **18-085-21** lead-acid battery with an on board charger
- IP65 external fan
- External charging indicator
- Universal input voltage: 110 or 220VAC
- Power from 720W to 1200W
- Ideal for electric vehicles in a variety of industrial applications

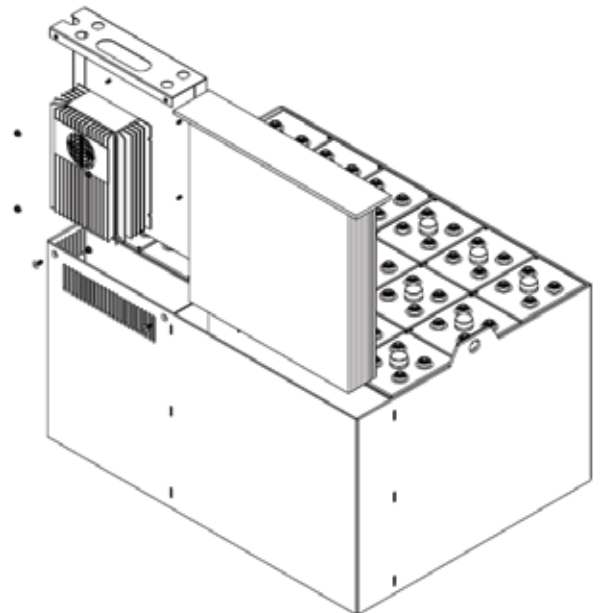

BATTERY TECHNICAL SPECIFICATIONS

BATTERY	18-085-21
TRAY	1999-B
COVER	No
EE SPARK PROOF	No
CABLE SIZE	3/0
BATTERY VOLTAGE	36V
AH CAPACITY	850
PLATE RATING AH	85
NUMBER OF CELLS	18
KWH	29.529



CHARGER TECHNICAL SPECIFICATIONS

BATTERY VOLTAGE	36V
CHARGER MODEL	36-30
BATTERY RANGE (5 HR)	255 - 320 AH
BATTERY RANGE (20 HR)	310 - 390 AH
CHARGING CURRENT	30A
DIMENSIONS (L X W X H")	11.02 x 4.13 x 8.98
WEIGHT (LBS)	12.13
INPUT VOLTAGE (50-60HZ)	110 / 220VAC
PROTECTION GRADE	IP65

18-085-21-1999-B DIMENSIONS

LENGTH (in)	WIDTH (in)	HEIGHT (in)
38.25	28.94	22.63

WEIGHT (lbs)
2842

